

100% of Actual Size  
Pad Print SIDE 1

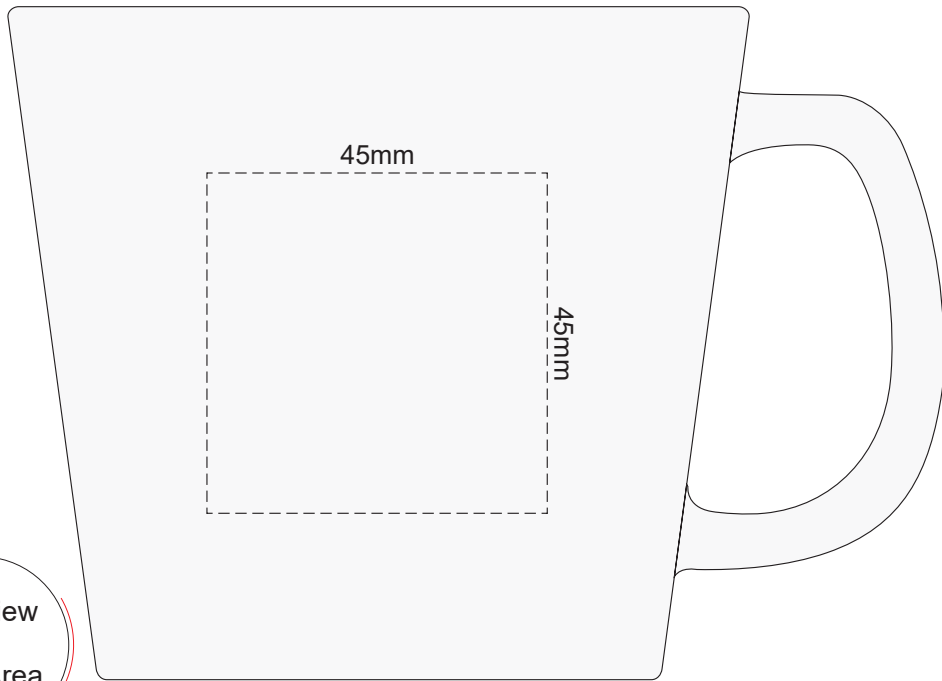

100% of Actual Size  
Pad Print SIDE 2

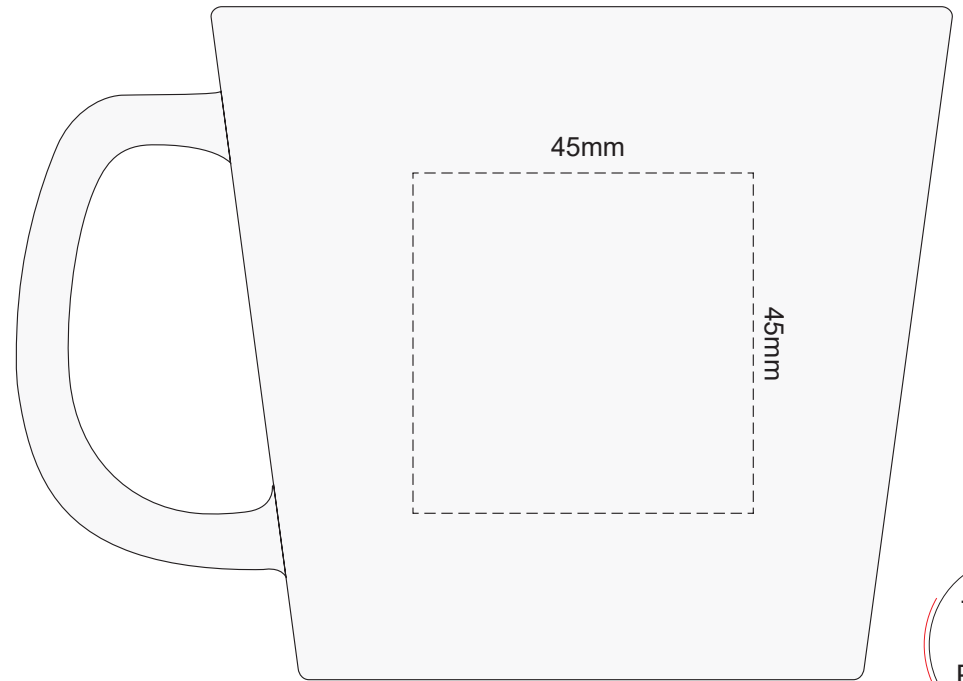

Top View  
of  
Print Area

Top View  
of  
Print Area

#### QUALITY OF CERAMICS

Due to the inherent properties of ceramic ware produced by foreign manufacturers, there may be small imperfections or irregularities which should not be perceived as defective. Variations in materials firing temperatures and colour pigment may result in glaze and imprint colour variations. These variations are considered acceptable.

100% of Actual Size  
Digital Packaging Print

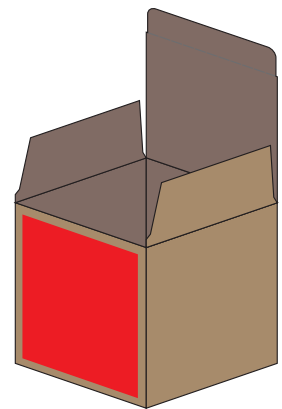
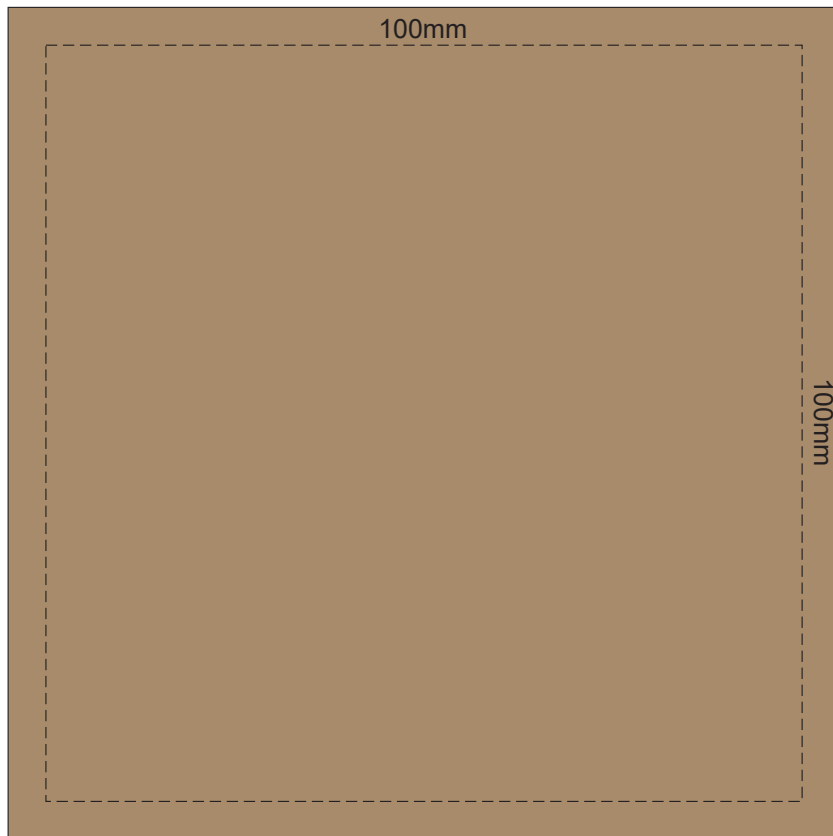

GIFT BOX  
FRONT

Artwork will be printed directly onto the product via CMYK printing (no white), colours will not be vibrant due to white ink not being available for this process.

# GIFT BOX SLEEVE

60% of Actual Size  
Digital Print  
423mm

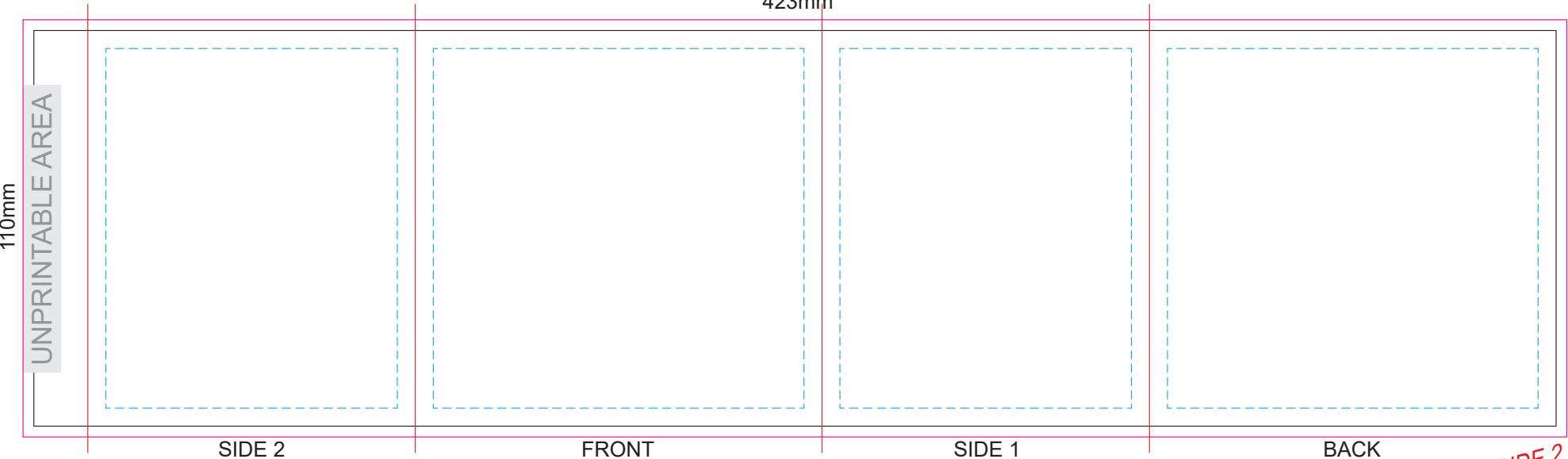

SIDE 2

FRONT

SIDE 1

BACK

Blue Line = The SIGNIFICANT PRINT AREA  
(Keep all critical images & text within this box)

Black Line = Maximum print area

Pink Line = Bleed off to here

Red Line = Fold Line

